

EARTH LEAKAGE MONITOR FOR DC UNEARTHED IT SYSTEMS

Type: DDEA

FEATURES

- **Monitors Insulation deterioration and faults and gives an early warning if a leak current exceeds a preset level**
- **Programmable leak current limit from 0.2 to 30 mA**
- **Universal unit for a wide range of distribution system voltages U_N from 20 to 500 V.**
- **Self-supplied from the distribution system**
- **Time delay - on and off - individually adjustable**
- **Relay function 2x1C/O (leak from + or -) or 1x2C/O**
- **The relays work in Fail Safe mode**
- **Latch function can be selected**
- **3-digit display shows actual current leak**
- **LEDs indicate the status of the relay, latch and timing function**

FUNCTION DIAGRAM

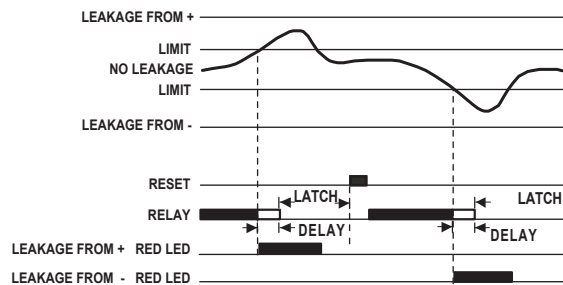

Description:

The DC earth leakage relay is designed to monitor unearthed DC IT systems for insulation deterioration or faults. The DDEA, that is power supplied from the system to be monitored, is connected to earth through an active current limited circuitry, trying to keep the earth voltage at half the system voltage. If there is a leak to ground from one of the supply lines the DDEA will compensate in order to keep the earth voltage at half the supply voltage. When the compensation current rises to a higher level than the set point the relay will switch, and the DDEA will let the earth float with the limited compensation current still running. This ensures that the special features of an unearthed system are still available while the fault can be found and repaired. The internal relays can be set to work in parallel for a fault or individually for faults in the positive or the negative line. In the unlikely case that there is a balanced leak from both the positive and the negative supply line it will not be detected by the DDEA.

Operation:

In order to minimize the size of the DDEA the unit is powered by 3 independent switch mode supplies. Two supplies are used to either source or drain current from the earth terminal and a third supply powers the electronics. The DDEA is with leak currents below 10mA either sourcing or draining with a DC current. At higher leak current, high supply voltage and high ambient temperature the DDEA automatically changes mode to a safe pulse pause mode where the pulses (leak and measuring current) are 600 msec and the pause up to 20 sec. or long enough to keep the temperature in the box below 65 °C.

If LATCH is selected the relays can be reengaged - if the leak current is under the set point - by pressing the S/R button on the front.

Application:

Unearthed systems can function even with a direct short from any point in the wiring to ground, but another short or leak from another point in the system can be fatal. Either direct with heavy currents, overheating or indirect through component malfunction. The DDEA solves the problem by monitoring the circuit and giving an early warning as soon as it senses a leak current greater than the set value. Securing the ground level at half system voltage reduces at the same time personal risks for electric shock.

CONNECTION DIAGRAM

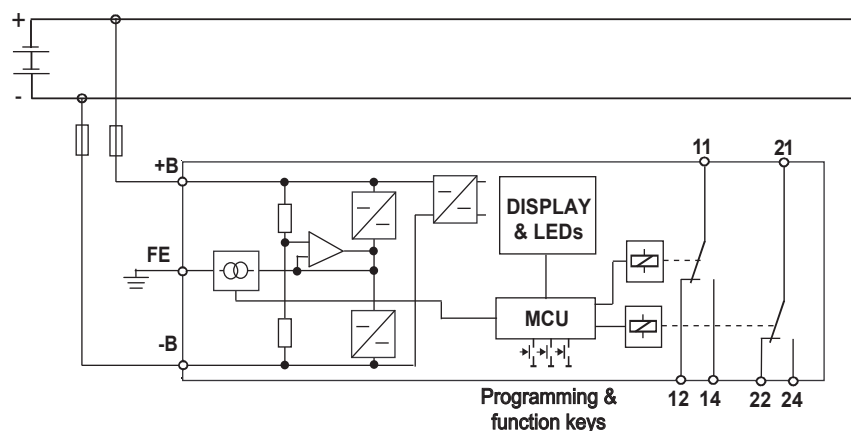

Please note

If the two relay contacts are in "Fault" position and all LED's are red and the display shows "FFF", then the DDEA is defect and must be replaced.

SPECIFICATIONS

INPUT

To Earth connector	DC Current up to set point then a floating DC Voltage
Set points	Programmable from 0,2 to 30 mA
Differential	Programmable from 0,1 to set point -0,1 mA
Voltage limit	Voltage on Earth connector FE must be limited to be within system voltage

PERFORMANCE PARAMETERS

TIMING	
Response time	Typical <200 msec. Below 10 mA and not pulsed earth leakage current. At higher current, voltage and ambient temperatures dependent on pause time. Max. 20 sec.
Time range during run	Programmable separate On and Off delay 0 - 99,9 sec. MCU controlled.

ELECTRICAL

Accuracy	Set point $\pm 2\%$ within system voltage
Temp. dependence	Typ. $\pm 0.02\%$ / °C

OUTPUT

RELAY	2 relays x 1C/O, AgNi/Au
Contact rating	6 A, 250 VAC, 1500 W
	See figure for DC rating
Mechanical life	20 million operations

ANALOG INDICATION

Display	3 digit LED
	Current resolution 0,1 mA
	Time resolution 0,1 sec.

SUPPLY

Supply range	20 - 500 V $\pm 10\%$
Power consumption	Max 3.5 W

GENERAL

Temperature range	- 25 °C to + 55 °C ambient
Humidity	Up to 90 % RH non-condensing
Dielectric test voltage	DC circuit to contact 4000 Vrms Contact to contact 2500 Vrms
Open contact circuit	1000 Vrms
Weight	0.17 kg.



International Standards

Product safety	EN 60255-27: 2006
EMC	EN 50263: 2000
	EN 60255-22 Immunity
	EN 61000-25 Emission

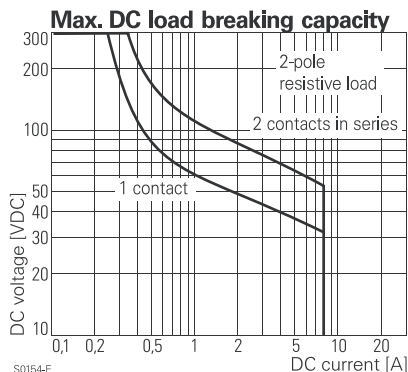

ORDERING INFORMATION

EXAMPLE:

TYPE
Differential DC current control relay

SUPPLY VOLTAGE
20 - 500 Vdc

ADJUSTMENT
Programmed

HOUSING
Rail mounting

SIZE
45 mm.

CODE END

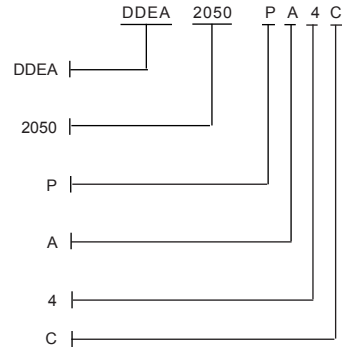

DDEA Set-up parameters

To enter Setup Menu pres S/R button for app. 5sec.

If no activity on the buttons for 50sec., then the setup will end without saving data. To return to factory default see below

Step 1: Set Trip to over current. Relay ON to OFF

LEDs: "Leakage to +" and "Leakage to -" are blinking Red
Set trip value from 0,1 to 30,0 mA

Press Up or Down keys to change trip value and press S/R for next Setup menu

Step 2: Set Return to acceptable current. Relay Off to ON

LEDs: "Leakage to +" and "Leakage to -" are blinking Green
Set return value 0,1 to "trip value" x,x mA

Press Up or Down keys to change trip value and press S/R for next Setup menu

Step 3: Set Delay time from ON to OFF

LEDs: "Relay Leakage to +" and "Relay Leakage to -" are blinking Red
Set OFF time delay from 0,0 to 99,9 sec.

Press Up or Down keys to change trip value and press S/R for next Setup menu

Step 4: Set Delay time from OFF to ON

LEDs: "Relay leakage to +" and "Relay leakage to -" are blinking Green
Set ON delay time from 0,0 to 99,9 sec.

Press Up or Down keys to change trip value and press S/R for next Setup menu

Step 5: Set Latch OFF (0) or ON (1)

If latch OFF all 4 LEDs are Green
If latch ON all 4 LEDs are Red

Press Up or Down keys to change latch setting and press S/R for next Setup menu

Step 6: Set Relay Function

Function 1: Individual functioning C/O contact for leakage to + and for leakage to -. Relay LEDs blinking Red and Green out of phase
Function 2: 2 parallel functioning C/O contacts for leakage to + or leakage to -. Relay LEDs are blinking Red and Green in phase

Press Up or Down keys to change the relay function and press S/R to Store Data and Exit setup

To return to factory default setup values press "S/R" and "UP" buttons simultaneously for app. 5 sec.

Over current trip:	10,0 mA
Return trip:	9,8 mA
Delay time ON to OFF:	2,0 sec.
Delay time OFF to ON:	2,0 sec.
Latch:	OFF (0)
Relay function:	Function 1 (Individual)