

BATTERY SYMMETRY MONITORING RELAY

Type: BMSA

FEATURES

- **Early warning for Cell deterioration like Sulphating or internal Short Circuit**
- **All in one unit by Multi Range from 24 to 512 Volt**
- **No current leak through the middle point connection**
- **Optional Over and Under voltage monitoring**
- **Easy set-up by keying in actual parameters or loading in through a RS 232 connection**
- **Time delay - On and Off - can be set individually**
- **Latched Relay function can be selected**
- **LEDs indicate the status of the relay, latch and timing function**
- **Reset and individual Test keys for +B and -B**
- **RoHS technology**
- **Extremely compact and low power consumption**

CONNECTION DIAGRAM

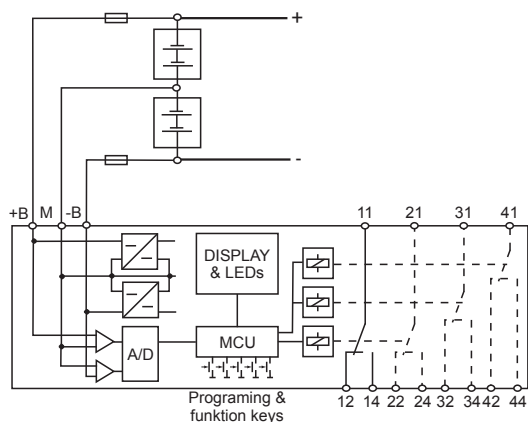

Contact information:

Symmetry relay: 11, 12, 14 and 21, 22, 24

Optional: Under voltage relay: 31, 32, 34. Excludes 21, 22, 24

Optional: Over voltage relay: 41, 42, 44. Excludes 21, 22, 24

For a healthy battery the following contacts will be closed:

11-14, 31-34 and 41-42

Description:

The multipurpose Battery Symmetry Relay BMSA is designed to monitor and give an early warning if one or more cells are performing different from an average cell in the battery. The battery must consist of two blocks of cells coupled in series with an accessible middle point used as a reference potential. No current will be drawn from the middle point. The Symmetry Relay monitors that the positive and the negative battery blocks perform equally independent of the actual charge and load level. The two battery blocks do not need to be of equal voltage (same number of cells), but the individual cells must be equal and have the same history. The BMSA accepts up to twice as many cells in one block as in the other. The nominal voltage range of each block can be set from 12V to 256V and the actual voltage must be within the range of 9 to 300V allowing a battery voltage ranging from 18V to 600V. For high battery voltages exceeding 300V the middle point connection is critical. If it can (even accidentally) be disconnected, the maximum battery voltage must be kept below 300V.

As an option, the BMSA can be extended to monitor the actual battery voltage for under and over voltage. The option will include individual relays for under and over voltage.

Operation:

When the BMSA is powered up for the first time it will need to be configured to the application. The configuration can be done either by using the keys on the front, or through a RS232 port in the side of the unit. When it is programmed it is ready to monitor the battery. For detailed information of the function of the Display and the LED's, please see the block diagram. The display will show the two battery block voltages, the total battery voltage and the average cell voltage difference between the two battery blocks in %. For each readout, the LED's on the front will indicate what the display is showing. The display can be set to show one particular measured value, or continuously cycle through the different measurements, one after the other in a specified time sequence. When the BMSA is connected to the battery, and the battery is OK, then the internal relay will pull in. When the cell difference exceeds the set maximum, the OFF delay will start to expire and the yellow LED "Toff" will be lit. After the set time delay the relay will drop out. Depending on the latch setting, the relay will remain out or may go in again if the battery returns to a healthy condition. The BMSA is constantly checking the battery connections and blinks with the LED: +B, -B or both LED's if the connection to battery plus, minus or the middle point is disconnected.

Test and Reset function:

The two test keys offset the measured voltage from either battery block by 10%. The display and the function of the BMSA will respond to the change with a new voltage and cell difference information and the relay will operate. The reset key is used for releasing the Latch function and for programming.

Application:

The BMSA is used on batteries in back up supplies where, by matching two batteries against each other, a warning can be given as soon as a cell in one of the battery blocks starts to deteriorate. As the BMSA is not depending on the actual charge and load status, it is a powerful supervision of only occasionally used batteries in emergency systems.

SPECIFICATIONS

INPUT	DC voltage
Set Range	2 x 12 Vdc to 2 x 256 Vdc. (Numbers of cells times cell voltage)
Functional Range	2 x 9 Vdc to 2 x 300 Vdc with the middle point "M" connected. Maximum short time voltage 2 x 350 Vdc or 1 x 350 Vdc (+B -B) if the middle point "M" is disconnected
Current	120 mA @ 2 x 9 Vdc 6 mA @ 2 x 300 Vdc
RS 232	Isolated. Used with special adapter and mini USB female connector.

PERFORMANCE PARAMETERS

RESOLUTION

For Set Range < or = 2 x 48 V	< ± 50 mV. Display voltage ± 0,1 V
For Set Range 48 V to 256 V	< ± 200 mV. Display voltage ± 1 V
Average cell diff. in %	< ± 0.5% @ 12V/70V and 48V/300V range < ± 0.1% @ 48V/70V and 256V/300V range
	Display average cell diff. ± 0.1%

TIMING

Response time	Typical < 200msec.
Time range	Separate On and Off delay setting 0.1 - 99.9 sec.

ELECTRICAL

Temp. dependence	A/D converting Typ. ± 0.02 % / °C
------------------	-----------------------------------

OUTPUT

RELAY	2 C/O or 3 x 1 C/O with Optional Over & Under Voltage monitoring
Contact rating	6 A, 250 VAC, 1500 W
Mechanical life	30 million operations

SUPPLY

	Self Supplied, DC voltage
Range	18 - 600V (300V if the middle point is not connected)
Fuse	Internal 2 x 250 mA in +B and -B
Power consumption	Breaking capacity 100 A / 250 Vdc Max 4 W

GENERAL

Temperature range	- 25 °C to + 55 °C ambient
Humidity	Up to 90 % RH non-condensing
Dielectric test voltage	Coil to relay contacts 4000 VAC
Pole to pole	2500 VAC
Weight	170 g standard 200 g with optional over and under voltage



Directive 2002/95/EC of
27. January 2003

EMC directive 89/336: Emission and Immunity EN50263:2000
EN61000-3-2
EN61000-3-3

Low voltage directive 73/23: Electrical Relays EN60255

ORDERING INFORMATION

EXAMPLE:

TYPE
Battery Symmetry Relay

SUPPLY VOLTAGE
18 V to 300 Vdc

ADJUSTMENT
Programmed

HOUSING
Rail mounting

SIZE
35 mm. Symmetry Relay only
45 mm. With optional Under & Over voltage

CODE
Code end
Extended code

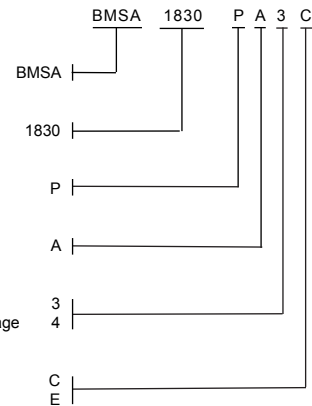

Functional diagram for battery symmetry relay type: BMSA

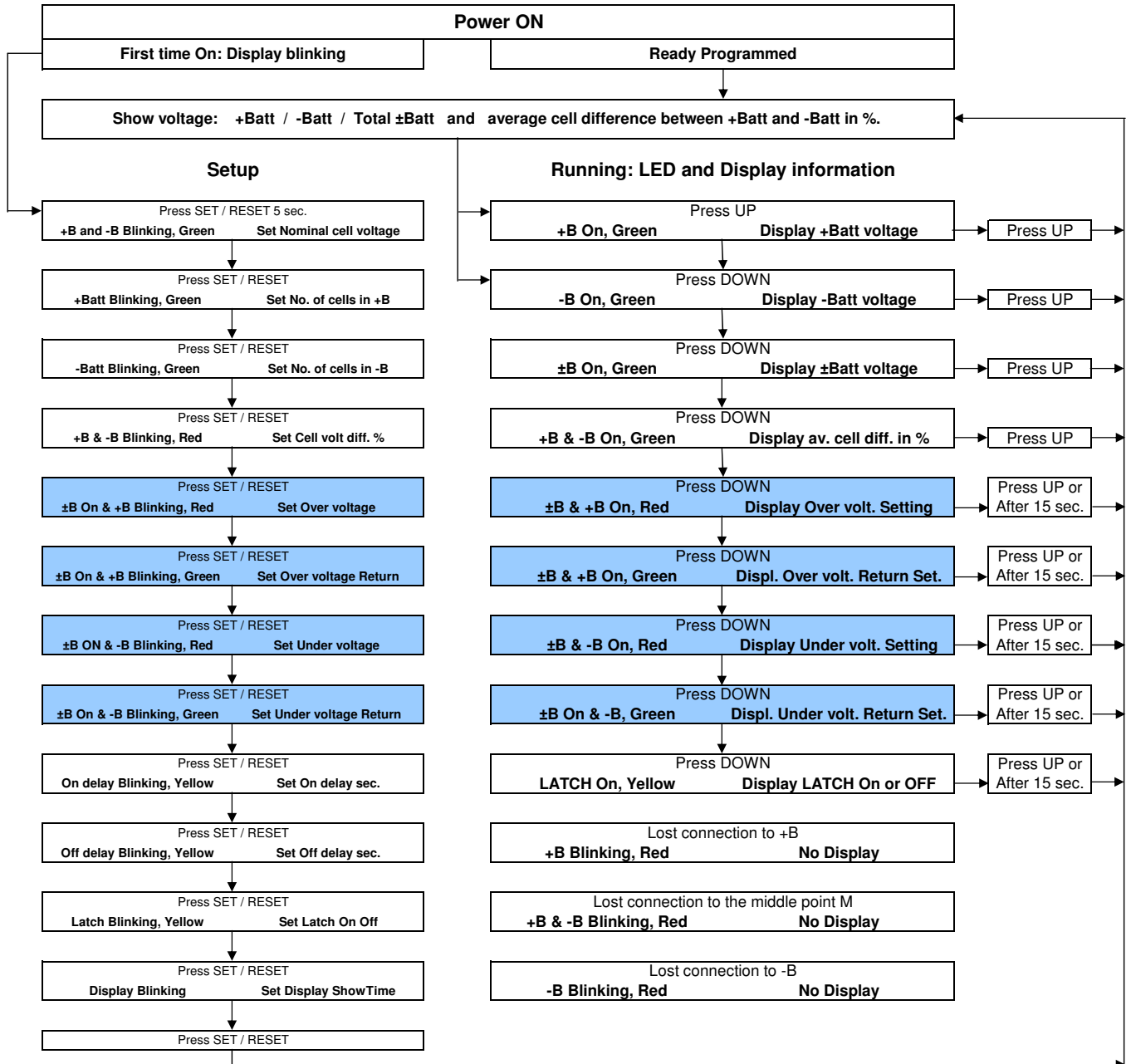

Definitions and limitations

Nominal cell voltage x.xx is used to calculate the voltage range to be used. The range is set according to the battery with the highest No. of cells.

If the battery has a total nominal voltage up to 48V, it will be measured in the 70V range.

If the battery has a total nominal voltage higher than 48V, it will be measured in the 300V range.

Number of cells times nominal voltage of the cells, must be within the range from 12V to 256V for each of the two Batteries.

The actual voltage of each of the two batteries must be within the range of 9 to 300 volts.

NOTE: If the middle point M is not connected or disconnected, the maximum voltage of ±B must be below 340V.

Cell voltage difference in % is the percentual difference between the average voltage of the cells in the + Battery compared to the cells in the - Battery.

The calculation is $(100 * ((Av. Cell + Batt) - (Av. Cell - Batt))) / (0.5 * ((Av. Cell + Batt) + (Av. Cell - Batt))) \%$.

Cell voltage difference in % can be set from 1% to 20%.

1% is equal to a cell voltage difference of 20mV for two cells of 2.0V and 120mV between two 12V batteries at 12V.

20% is equal to a cell voltage difference of 400mV for two cells of 2.0V and 2,4V between two 12V batteries at 12V.

The resolution of the voltage measurement is calculated up to 70V to be $70/4096 = 17.1\text{mV}$. In the range up to 300V it is 73.2mV.

The practical resolution over the temperature range is 2 to 3 times the calculated values.

Time delay ON or OFF can be set from 0.1 to 99.9 sec.

Less than 0,1mA will be drawn from the middle point. Total supply will be taken from the +B and -B.

Optional

Over and under voltage measuring with one separate relay for each function.

