



**iSN-101      iSN-101/DIN**  
Liquid Leak Detection Module

### Introduction

The iSN-101 Liquid Leak Detection Module is a low-cost intelligent liquid leak detection device that can be used to directly control Relay Output. No additional conversion module is needed and the iSN-101 can be easily integrated with a variety of monitoring systems to achieve remote alarm and remote device control. The iSN-101 Liquid Leak Detection module can be used to monitor double-core leader cable lengths of up to 500 meters, and can be used with both the extended cable and its included liquid leak detection cable. If liquid is detected, the controller immediately activates the output relay - the normally open, normally closed passive output signal. The module can be easily integrated with other collection hosts connected to the network. The iSN-101 is suitable for real-time leak detection in critical locations, such as computer room base stations, warehouses, libraries, museums and industrial sites, and also for air handling equipment, refrigeration units, liquid containers, or pump tanks, etc., where there is a need to monitor any leakage of the equipment.

When required, communication with the iSN-101 can be programmed based on the Modbus RTU protocol, with the added benefit that different addresses can be configured via hardware to allow for Modbus RTU communication.

### Configuration



DIP Switch Description			
	SW1	ON	DCON Protocol
		OFF	Modbus RTU Protocol
	SW2	ON	Software Configuration
		OFF	Hardware Configuration
SW3	ON	High Node Address	
	OFF	Low Node Address	
SW4	ON	INIT Mode	
	OFF	Normal Mode	

### Features

- 1-ch Liquid Leak Detection
- Water Leakage detection triggers and audible alarm
- A mute button to silence the audible alarm
- Two LED indicators to display the status of the power and the alarm
- Relay Output for Water Leakage Alarm
- Liquid Leak Detection Cable and Extended Cable can be up to 500 meters
- Sensitivity adjustable detection
- Supports the DCON and the Modbus RTU Protocols
- Embedded Dual Watchdog



### Specifications

EMS Protection	
EFT (IEC 61000-4-4)	±4 kV for Power
ESD (IEC 61000-4-2)	±8 kV Air for Random Point
LED Indicators	
Status	1 as Power Indicator 1 as Alarm Indicator
System	
Alarm	For both liquid leak detection and cable-break detection.
Buzzer	Yes. Can be muted by a push button.
Relay Output	Signal Relay, Form A x1, SPST 0.25 A @ 250 VAC 0.5 A @ 125 VAC 2 A @ 30 VDC
Liquid Leak Detection	
Channels	1
Liquid Type	Water, 2 uS/cm
Sensor Type	Probe for point detection or Cable for line detection
Max. Cable Length	500 meters Include Liquid Leak Detection Cable and Extended Cables.
Sensitivity Range	26 KΩ ~ 580 KΩ (adjustable by rotary switch)
Cable-break Detection	Yes. For Liquids Leak Detection Cable CA-LLD-DC100X-Lxxx only.
COM Ports	
Ports	1 x RS-485
Baud Rate	Software Configuration: 1200 ~ 115200 bps
Data Format	(N,8,1), (O,8,1), (E,8,1), (N,8,2)
Protocol	Modbus RTU or DCON
Power	
Reverse Polarity Protection	Yes
Input Range	10 ~ 30 VDC
Consumption	1.5 W Max.
Mechanical	
Dimensions (mm)	83 x 70 x 29 (W x L x H)
Installation	Screw Mounting
Environmental	
Operating Temperature	-25 ~ +75 °C
Storage Temperature	30 ~ +80°C
Humidity	10 ~ 90% RH, Non-condensing

## Applications

The iSN-101 is a leakage detection module used in water pipe leak monitoring in buildings with two working modes.

1. Work with the Liquids Leak Detection Cable that installed near the possible leaking pipe or area to detect leakage with alarm.
2. Work with the leakage probe that installed in fixed possible leak locations to detect.

The leakage monitoring is applied to the water pipes, fire pipes and sewage pipes of buildings, as well as the detecting of domestic water, drainage and electric equipment, which can effectively achieve water saving and ensure the safety of living. The iSN-101 can detect leakages, send out signal and alarms, combine with the WISE IoT Edge Controller or TPD/VPD Touch HMI, and to further integrate with the mobile APP or community system.

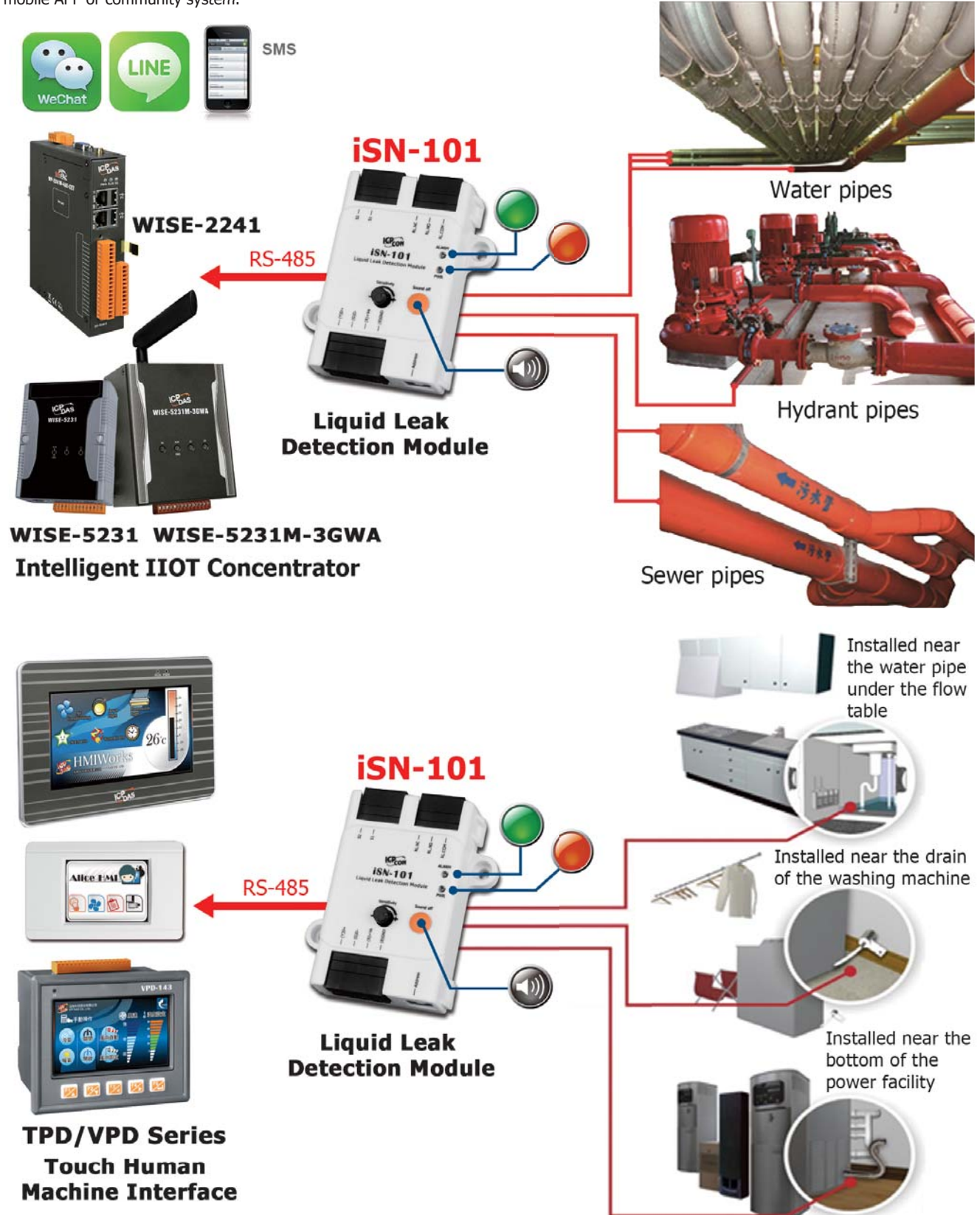

## Wire Connections

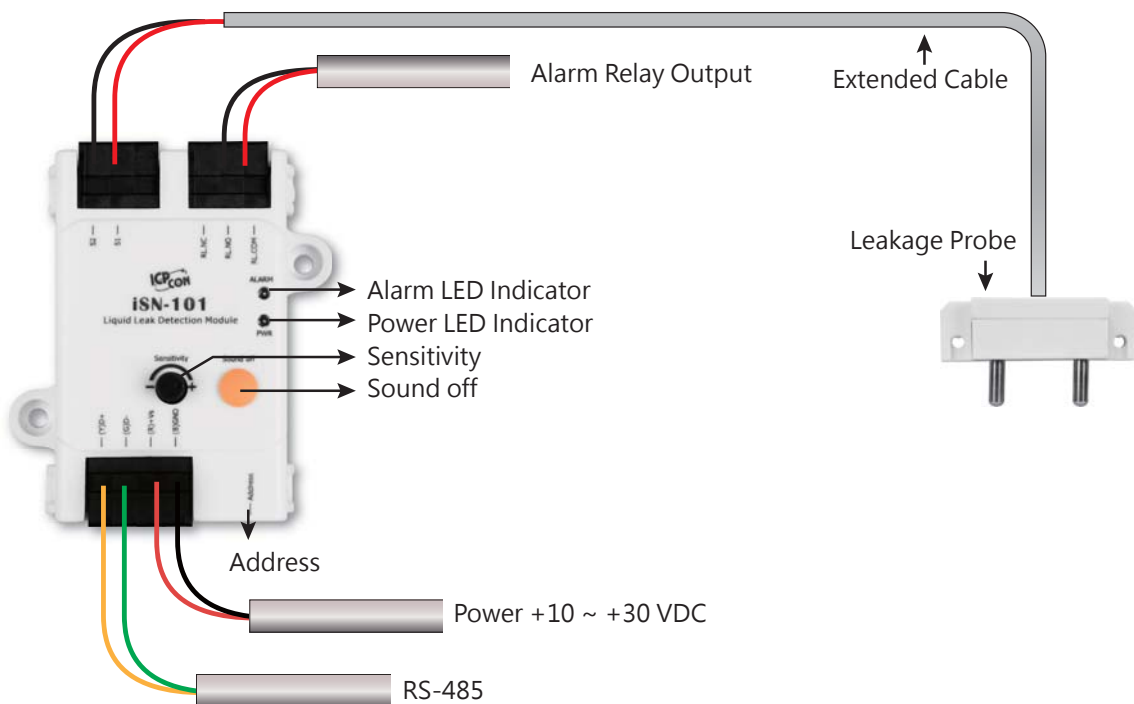
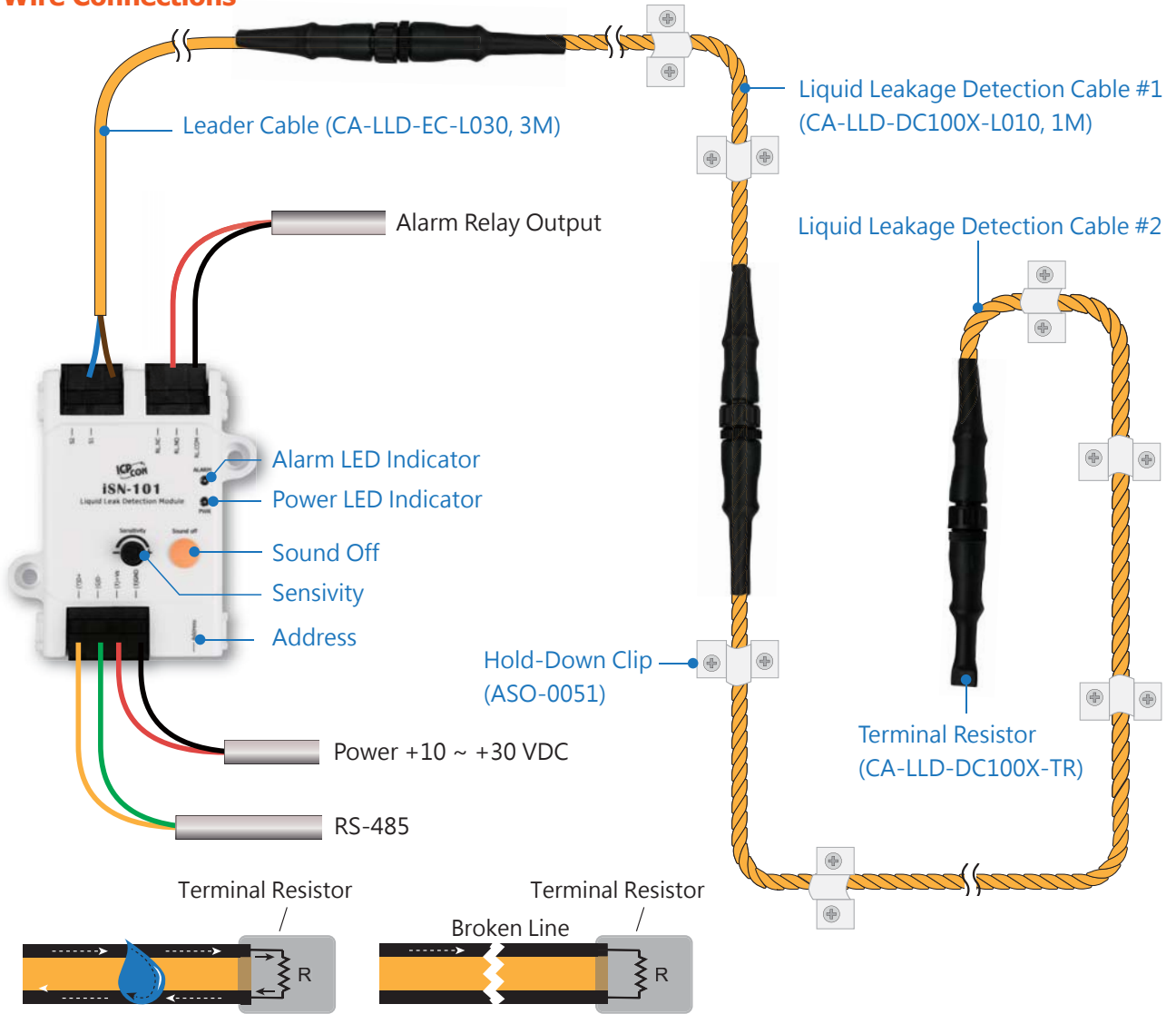

## ■ Dimensions (Units: mm)/PIN Assignments

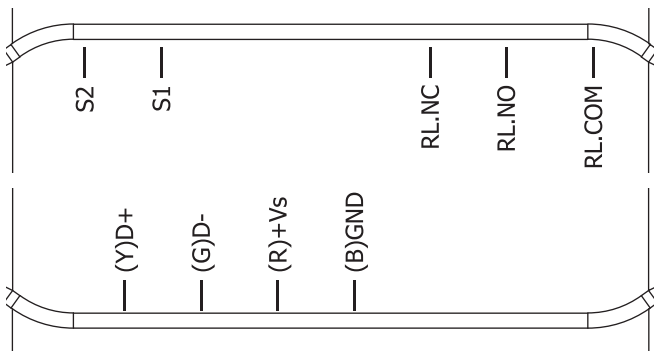
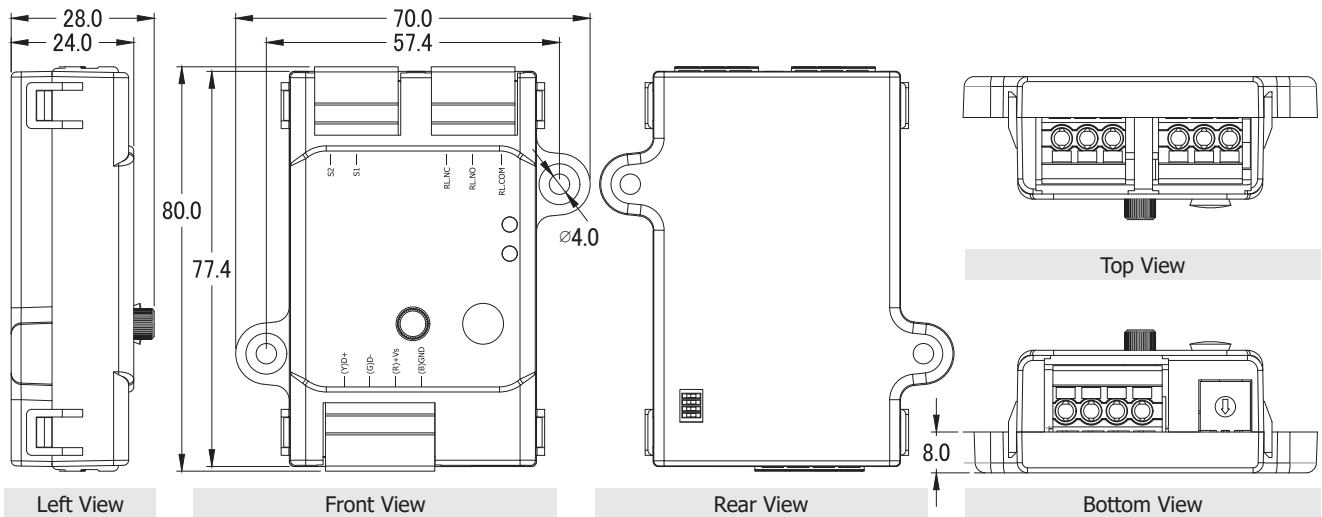

## ■ Ordering Information

<b>iSN-101 CR</b>	1-channel Liquid Leak Detection Module (RoHS)
<b>iSN-101/DIN CR</b>	1-channel Liquid Leak Detection Module (DIN Rail mount) (RoHS)
<b>iSN-101/S CR</b> <b>iSN-101/S/DIN CR</b>	1-channel Liquid Leak Detection Module (RoHS) Includes an iSN-101 Module, a 1 m Liquid Leak Detection Cable and 3m Extended Cable.
<b>iSN-101/S2 CR</b> <b>iSN-101/S2/DIN CR</b>	1-channel Liquid Leak Detection Module (RoHS) Includes an iSN-101 Module, a 3 m Liquid Leak Detection Cable and 3m Extended Cable.
<b>iSN-101/S3 CR</b> <b>iSN-101/S3/DIN CR</b>	1-channel Liquid Leak Detection Module (RoHS) Includes an iSN-101 Module and a Leakage Probe.

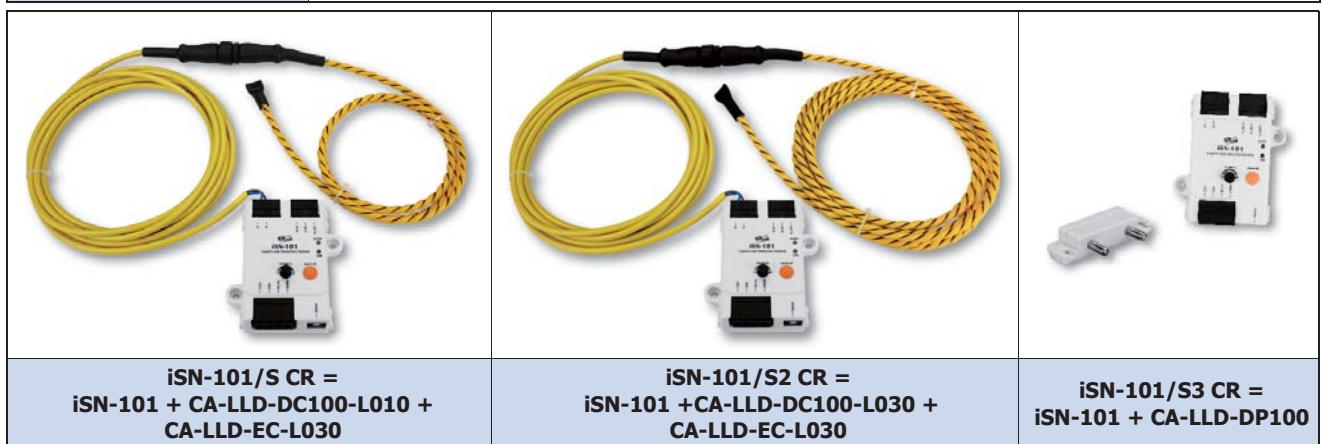

### Accessories

	tM-7520U CR	RS-232 to RS-485 converter (RoHS)		CA-LLD-DC100-L100 CA-LLD-DC100-L300 CA-LLD-DC100-L500	Liquids Leak Detection, Water Detection Cable w/o Position, 10 m /30 m /50 m length
	tM-7561 CR	USB to RS-485 converter (RoHS)		CA-LLD-DC100X-L010 CA-LLD-DC100X-L030 CA-LLD-DC100X-L100 CA-LLD-DC100X-L300 CA-LLD-DC100X-L500	Liquids Leak Detection, Water Proof Plug Male to Female Cable, 1 m/ 3 m/ 10 m/ 30 m /50 m (RoHS)
	I-7514U CR	4-channel RS-485 Hub (RoHS)		CA-LLD-EC-L030	Leader Cable, 3 m (RoHS)
	ASO-0052	90 Hold-Down Clip (include 50 pcs) (RoHS)		CA-LLD-DC100X-TR	Terminal Resistor, 2 MΩ (RoHS)
	ASO-0051	180 Hold-Down Clip (include 50 pcs) (RoHS)		CA-LLD-DP100	Leakage Probe (RoHS)

Liquids Leak Detection = LLD

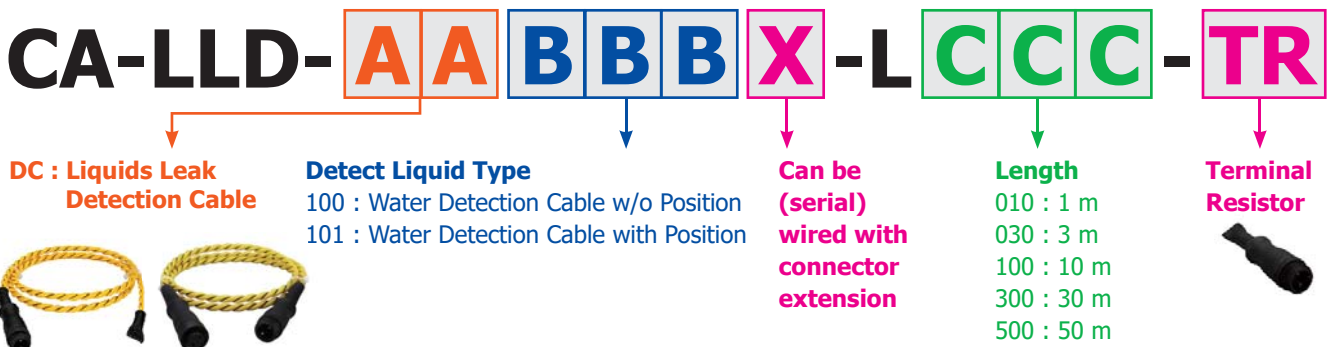

**EC : Extension Cable**



**DP : Detection Probe**

