



tM-P4C4

4-channel Isolated Digital Input and 4-channel Isolated Digital Output Module

Introduction

The tM-P4C4 provides 4 channels for digital input and 4 channels for digital output, each of which features photocouple isolation. The tM-P4C4 supports sink type output with short circuit protection, while input is source type. All input channels can be used as 16-bit counters. There are options for configuring power-on and safe digital output values. 4 kV ESD protection and 3750 V_{DC} intra-module isolation are also provided.

Applications

- All kinds of On/Off Control
- Industry Automation
- Industrial Machinery
- Building Automation
- Food & Beverage Systems
- Semiconductor Fabrication
- Control Systems

System Specifications

Communication	
Interface	RS-485
Format	(N, 8, 1), (N, 8, 2), (O, 8, 1), (E, 8, 1)
Baud Rate	1200 ~ 115200 bps
Protocol	DCON, Modbus/RTU, Modbus/ASCII
Dual Watchdog	Yes, Module (2.3 seconds), Communication (Programmable)
LED Indicators	
Power	1 LED as Power Indicator
Isolation	
Intra-module Isolation, Field-to-Logic	3750 V _{DC}
EMS Protection	
ESD (IEC 61000-4-2)	±4 kV Contact for each terminal ±8 kV Air for random point
EFT (IEC 61000-4-4)	±4 kV for Power
Power Requirements	
Reverse Polarity Protection	Yes
Powered from Terminal Block	Yes, 10 ~ 30 V _{DC}
Consumption	0.5 W max.
Mechanical	
Dimensions (W x L x H)	52 mm x 98 mm x 27 mm
Installation	DIN-Rail Mounting
Environment	
Operating Temperature	-25 ~ +75 °C
Storage Temperature	-30 ~ +75 °C
Humidity	10 ~ 95% RH, non-condensing

Digital Input & Digital Output

Features

- Sink Type Digital Outputs
- Source Type Digital Inputs
- Photocouple Isolation
- All Channels Can Be Used As 16-bit Counters
- Dual Watchdog
- Configurable Power-on Value Settings
- Configurable Safe Value Settings
- Cost-effective
- Wide Operating Temperature Range: -25 °C ~ +75 °C



Pin Assignments

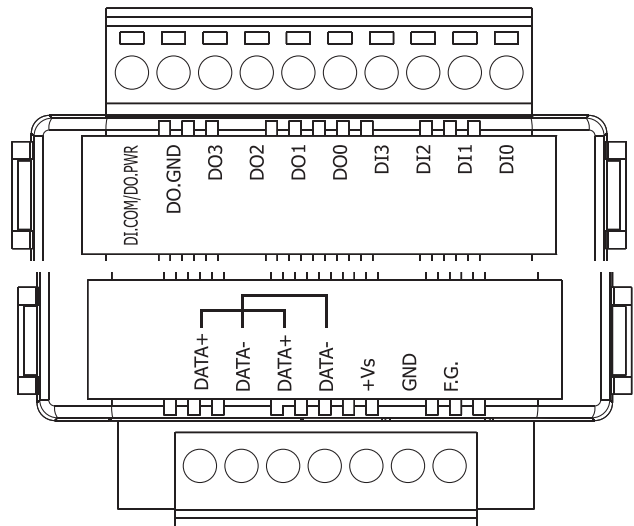

I/O Specifications

Digital Input/Counter		
Input Channels	4	
Type	Wet Contact (Source)	
On Voltage Level	+3.5 V _{DC} ~ 50 V _{DC}	
Off Voltage Level	+1 V max.	
Input Impedance	10 KΩ, 0.66 W	
Counters	Channels	4
	Max. Count	65535 (16-bit)
	Max. Input Frequency	100 Hz
	Min. Pulse Width	5 ms
Overvoltage Protection	70 V _{DC}	
Digital Output		
Output Channels	4	
Type	Isolated Open Collector (Sink)	
Max. Load Current	700 mA/channel	
Load Voltage	3.5 V _{DC} ~ 50 V _{DC}	
Overvoltage Protection	60 V _{DC}	
Overload Protection	Yes	
Short Circuit Protection	Yes	
Power-on Value	Yes, Programmable	
Safe Value	Yes, Programmable	

Dimensions (Unit: mm)

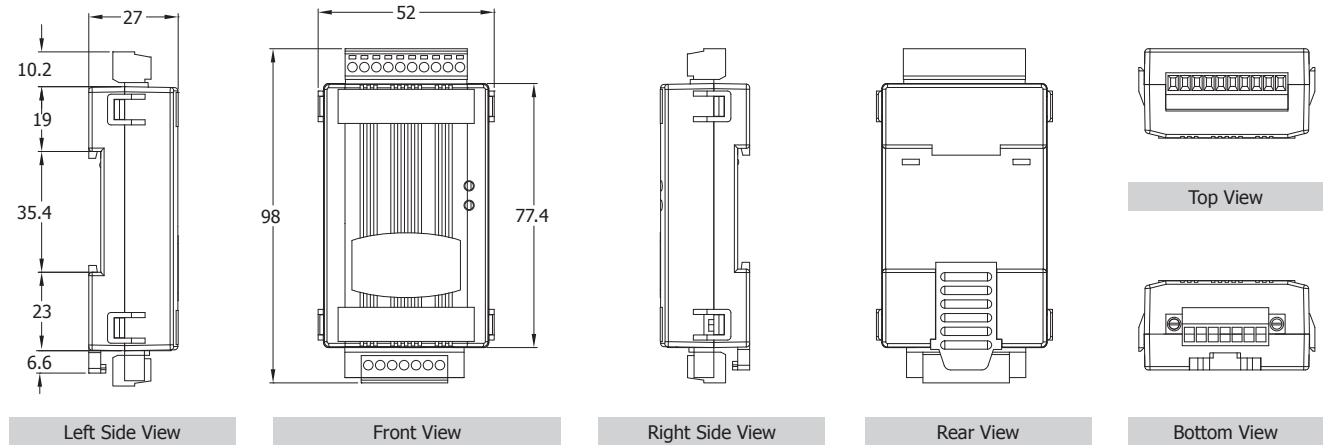

2

Tiny RS-485 Remote I/O Modules

Wire Connection

Digital Input/Counter	ON State Readback as 1	OFF State Readback as 0
Source	+3.5 ~ +50 V _{DC}	OPEN or <1 V _{DC}
Output Type	ON State Readback as 1	OFF State Readback as 0
Drive Relay	Relay ON	Relay OFF
Resistance Load		

3

tM Series

Ordering Information

tM-P4C4 CR	4-channel Isolation Digital Input and 4-channel Isolation Digital Output Module (RoHS)
------------	----------------------------------------------------------------------------------------

Related Products

	tM-7561 CR	Isolated USB to RS-485 Converter (RoHS)		tM-7510U CR	Isolated RS-485 Repeater (RoHS)
	tM-7520U CR	Isolated RS-232 to RS-485 Converter (RoHS)		MDR-20-24 CR	24W Single Output Industrial DIN Rail Power Supply (RoHS)

tM-P4C4