

# UC-8418 Series

**RISC-based industrial embedded computers with 8 serial ports, 3 LANs, DIO, 2 CAN Ports, CompactFlash, USB**



- > Intel XScale IXP435 533 MHz processor
- > 256 MB DDR2 SDRAM and 16 MB Flash ROM onboard
- > 32 MB NAND Flash for data storage
- > 256 KB battery backup SRAM
- > 8 RS-232/422/485 serial ports
- > 2 CANbus ports
- > 12 digital input and 12 digital output channels
- > 3 10/100 Mbps Ethernet ports
- > 2 USB 2.0 hosts for mass storage devices
- > CompactFlash socket for storage expansion
- > Ready-to-run Linux platform
- > DIN-Rail or wall mounting installation
- > Robust, fanless design
- > -40 to 75°C wide temperature model available



## Overview

The UC-8418 embedded computer comes with 8 RS-232/422/485 serial ports, 3 Ethernet ports, 2 CAN ports, 12 digital input channels, 12 digital output channels, a CompactFlash socket, and 2 USB 2.0 hosts.

The computer uses the Intel XScale IXP435 533 MHz RISC CPU. This powerful computing engine supports several useful communication functions, but will not generate too much heat. The built-in 16 MB NOR Flash ROM and 256 MB SDRAM give you enough memory to run your application software directly on the UC-8410, and the 32 MB NAND Flash can be used to provide additional data storage. Moreover, the 256 KB SRAM offers a better data retention mechanism for avoiding

data loss. The UC-8418 computer comes with 8 RS-232/422/485 serial ports, digital I/O, and has 3 LAN ports and 2 CANbus ports, making it ideal as a communication platform for industrial applications that require network redundancy.

The UC-8418 comes with the Linux 2.6 platform pre-installed to provide an open software operating system for software program development. Software written for a desktop PC can be easily ported to the UC-8418 platform by using a common compiler, without needing to modify the code. This makes the UC-8418 an optimal solution for use with industrial applications, but with minimal cost and effort. In addition to the standard model, UC-8418 also comes in a -40 to 75°C wide temperature model for harsh industrial environments.

## Appearance

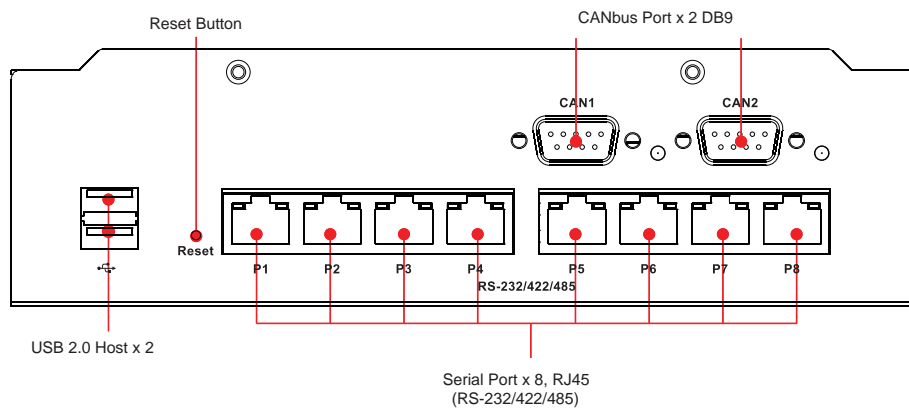

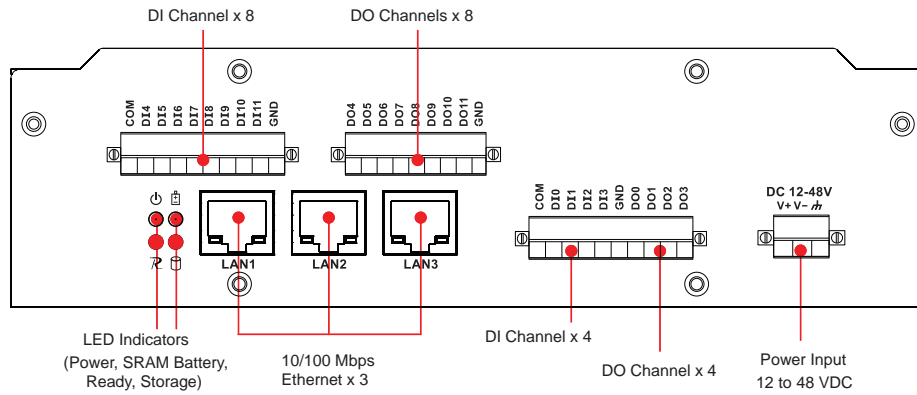

## Hardware Specifications

### Computer

- CPU:** Intel XScale IXP435, 533 MHz
- OS (pre-installed):** Linux
- DRAM:** 256 MB DDR2 SDRAM onboard (supports DDR2 up to 512 MB)
- SRAM:** 256 KB, battery backup
- Flash:**
  - 16 MB NOR Flash onboard to store OS (supports up to 32 MB)
  - 32 MB NAND Flash onboard to store data
- USB:** USB 2.0 full speed x 2 (OHCI)

### Storage

- Storage Expansion:** CompactFlash socket

### Ethernet Interface

- LAN:** 3 auto-sensing 10/100 Mbps ports (RJ45)

- Magnetic Isolation Protection:** 1.5 KV built-in

### Serial Interface

- Serial Standards:** 8 RS-232/422/485 ports, software-selectable (8-pin RJ45)

- Console Port:** RS-232 (TxD, RxD, GND), 4-pin header output (115200, n, 8, 1)

### Serial Communication Parameters

- Data Bits:** 5, 6, 7, 8
- Stop Bits:** 1, 1.5, 2
- Parity:** None, Even, Odd, Space, Mark
- Flow Control:** RTS/CTS, XON/XOFF, ADDC® (automatic data direction control) for RS-485
- Baudrate:** 50 bps to 921.6 Kbps (supports non-standard baudrates; see user's manual for details)

### Serial Signals

- RS-232:** TxD, RxD, DTR, DSR, RTS, CTS, DCD, GND
- RS-422:** TxD+, TxD-, RxD+, RxD-, GND
- RS-485-4w:** TxD+, TxD-, RxD+, RxD-, GND
- RS-485-2w:** Data+, Data-, GND

### Digital Input

- Input Channels:** 12, source type
- Input Voltage:** 0 to 30 VDC
- Digital Input Levels for Dry Contacts:**
  - Logic level 0: Close to GND
  - Logic level 1: Open
- Digital Input Levels for Wet Contacts:**
  - Logic level 0: +3 V max.
  - Logic level 1: +10 V to +30 V (COM to DI)
- Connector Type:** 10-pin screw terminal block (4 points, COM, GND)
- Isolation:** 3 KV optical isolation

### Digital Output

- Output Channels:** 12, sink type
- Output Current:** Max. 200 mA per channel
- On-state Voltage:** 24 VDC nominal, open collector to 30 V
- Connector Type:** 10-pin screw terminal block (4 points, GND)
- Isolation:** 3 KV optical isolation

### CANbus Communication

- Interface:** Dual optically isolated CAN2.0A/2.0B compliant ports
- CAN Controller:** Phillips SJA1000T
- Signals:** CAN-H, CAN-L
- Protocols:** Supports CANOpen library
- Isolation:** 2 KV optical isolation
- Speed:** 10 Kbps to 1 Mbps
- Connector Type:** DB9 male

### LEDs

- System:** Power, Ready, Storage, Battery for SRAM
- LAN:** 10M/Link x 2, 100M/Link x 2 (on connector)
- Serial:** TxD x 8, RxD x 8
- Reset Button:** Supports "Reset to Factory Default"

### Physical Characteristics

- Housing:** SECC sheet metal (1 mm)
- Weight:** 1 kg
- Dimensions:** 200 x 56 x 120 mm (7.87 x 2.20 x 4.72 in)
- Mounting:** DIN-Rail, wall

### Environmental Limits

- Operating Temperature:**
  - Standard Models: -10 to 60°C (14 to 140°F)
  - Wide Temp. Models: -40 to 75°C (-40 to 167°F)
- Operating Humidity:** 5 to 95% RH
- Storage Temperature:**
  - Standard Models: -20 to 75°C (-4 to 167°F)
  - Wide Temp. Models: -40 to 85°C (-40 to 185°F)
- Anti-Vibration:** 2 g rms @ IEC-68-2-34, random wave, 5-500 Hz, 1 hr per axis
- Anti-Shock:** 20 g @ IEC-68-2-27, half sine wave, 11 ms

### Power Requirements

- Input Voltage:** 12 to 48 VDC (3-pin terminal block)
- Power Consumption:** 15 W
  - 310 mA @ 48 VDC
  - 620 mA @ 24 VDC
  - 1350 mA @ 12 VDC

### Regulatory Approvals

- EMC:** CE (EN55022 Class B, EN55024-4-2, EN55024-4-3, EN55024-4-4), FCC (Part 15 Subpart B, Class B)
- Safety:** UL/cUL (UL60950-1), CCC (GB9254, GB 17625.1), LVD (EN60950)

## Reliability

**Alert Tools:** Built-in buzzer and RTC (real-time clock)  
**Automatic Reboot Trigger:** Built-in WDT (watchdog timer)

## Warranty

**Warranty Period:** 5 years  
**Details:** See [www.moxa.com/warranty](http://www.moxa.com/warranty)

**Note:** The Hardware Specifications apply to the embedded computer unit itself, but not to accessories. In particular, the wide temperature specification does not apply to accessories such as the power adaptor and cables.

## Software Specifications

### Linux

**Kernel Version:** 2.6.23  
**Protocol Stack:** TCP, UDP, IPv4, SNMP V1, ICMP, ARP, HTTP, CHAP, PAP, SSH 1.0/2.0, SSL, DHCP, NTP, NFS, Telnet, FTP, PPP, PPPoE, OpenVPN  
**File System:** JFFS2, NFS, Ext2, Ext3, VFAT/FAT  
**System Utilities:** bash, busybox, tinylogin, telnet, ftp, ssh, scp  
**telnetd:** telnet Server daemon  
**ftpd:** FTP server daemon  
**sshd:** secure shell server

**Apache:** web server daemon, supporting PHP and XML  
**openvpn:** virtual private network service manager  
**pppd:** dial in/out over serial port daemon  
**snmpd:** snmpd agent daemon  
**openssl:** open SSL  
**Application Development Software:** Moxa Linux API device control

### Linux Tool Chain:

- GCC (V4.2.1): C/C++ PC Cross Compiler
- Glibc (V2.2.5): POSIX standard C Library
- GDB (V6.3): source level debug server

## Dimensions (unit = mm)

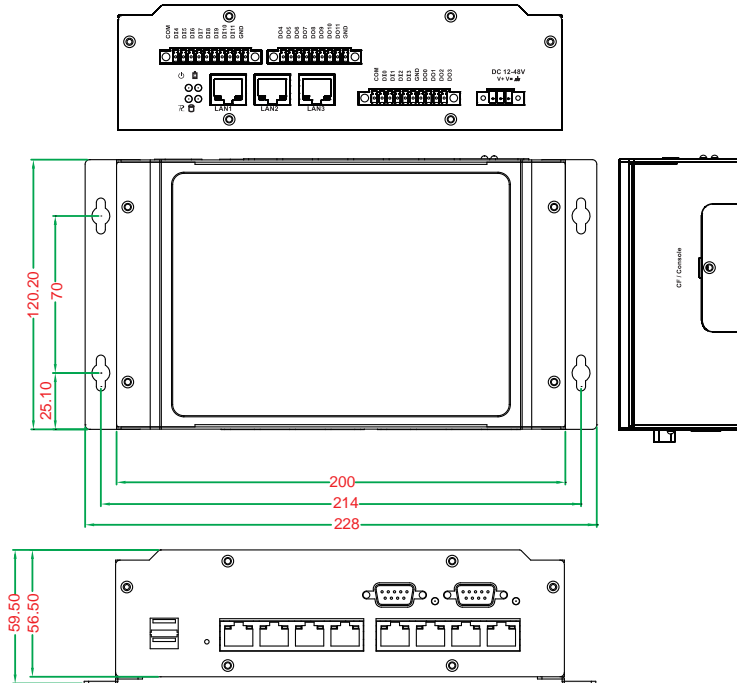

## Ordering Information

### Available Models

**UC-8418-LX:** RISC-based industrial embedded computer with 8 serial ports, 12 DIs, 12 DOs, 3 LANs, 2 CAN ports, CompactFlash, USB, Linux OS, -10 to 60°C operating temperature  
**UC-8418-T-LX:** RISC-based industrial embedded computer with 8 serial ports, 12 DIs, 12 DOs, 3 LANs, 2 CAN ports, CompactFlash, USB, Linux OS, -40 to 75°C operating temperature

### Package Checklist

- UC-8418 computer
- Wall mounting kit
- DIN-Rail mounting kit
- Ethernet cable: RJ45 to RJ45 cross-over cable, 100 cm
- CBL-4PINDB9F-150: 4-pin pin header to DB9 female console port cable, 150 cm
- Universal Power Adaptor (including power jack converter)
- Document and Software CD
- Quick Installation Guide (printed)
- Warranty Card