

UC-7122/7124 Series

Mini RISC-based ready-to-run computer with dual LANs, 2 or 4 serial ports, SD, USB



- > Cirrus Logic EP9302 ARM9 32-bit 200 MHz processor
- > On-board 32 MB RAM, 16 MB flash disk
- > 2 or 4 software-selectable RS-232/422/485 serial ports
- > 50 bps to 921.6 Kbps baudrate (non-standard baudrates supported)
- > Dual 10/100 Mbps Ethernet for network redundancy
- > SD socket for storage expansion supported
- > Built-in real-time clock (RTC), buzzer, watchdog timer (WDT)
- > Ready-to-run WinCE 5.0 platform
- > -40 to 75°C wide temperature models available



Overview

The UC-7122/7124 embedded computers come with 2 or 4 RS-232/422/485 serial ports and dual 10/100 Mbps Ethernet LAN ports to provide users with a versatile communication platform, making these RISC-based embedded computers ideal for your embedded applications.

The UC-7122/7124 embedded computers use the Cirrus Logic EP9302 ARM9 200 MHz RISC CPU. Unlike the X86 CPU, which uses a CISC design, the ARM9's RISC design architecture and modern semiconductor technology provide the UC-7122/7124 with a powerful computing engine and communication functions, but without generating too much heat. Moreover, the built-in 16 MB NOR Flash ROM and 16 MB SDRAM give you enough storage capacity to run applications on the UC-7122/7124 computers. The additional SD socket provides the flexibility of adding storage expansion disks, and the dual LAN ports built into the ARM9 make the UC-7122/7124 ideal communication platforms for simple data acquisition and protocol conversion applications. In addition, the

RS-232/422/485 serial ports allow you to connect a variety of serial devices. Taken together, these features ensure that the UC-7122/7124 embedded computers are convenient and powerful central control units for industrial applications, such as data acquisition, remote device control and monitoring, and protocol conversion.

The pre-installed WinCE 5.0 operating system provides a common Windows-based software operating system for software program development. This means that software written in Visual C/C++ for desktop PCs is easily ported to the UC-7122/7124 computers with a general programming tool such as Microsoft Embedded Visual C++ or Microsoft Visual Studio 2005. You will not need to spend time modifying existing software code, and the operating system, device drivers, and your own software can all be stored in the UC-7122/7124's flash memory.

Appearance

UC-7122

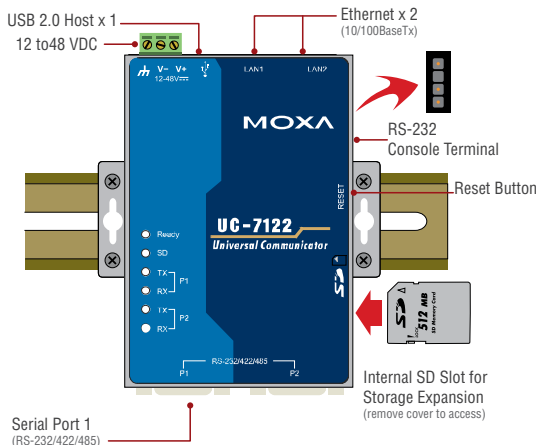

UC-7124

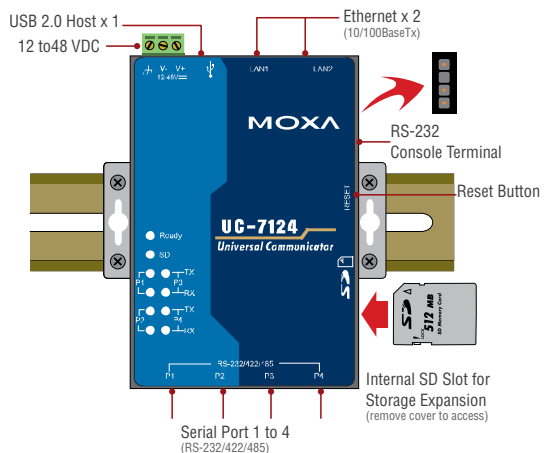

Hardware Specifications

Computer

CPU: Cirrus EP9302 ARM9 CPU, 200 MHz
OS (pre-installed): Windows CE 5.0
DRAM: 32 MB onboard (64 MB for ODM)
Flash: 16 MB onboard (32 MB for ODM)
Storage Expansion: SD socket
USB: USB 2.0 full speed Host (OHCI)

LAN Interface

Ethernet: Auto-sensing 10/100 Mbps x 2, RJ45 connectors
Magnetic Isolation Protection: 1.5 KV built-in

Serial Interface

Number of Ports: 2 or 4
Serial Standards: RS-232/422/485, software-selectable
Connectors: 8-pin RJ45
ESD Protection: 15 KV for all signals
Console/Debugging Port: RS-232 (TxD, RxD, GND), 4-pin pin header output

Serial Communication Parameters

Data Bits: 5, 6, 7, 8
Stop Bits: 1, 1.5, 2
Parity: None, Even, Odd, Space, Mark
Flow Control: RTS/CTS, XON/XOFF, ADDC™ (automatic data direction control) for RS-485
Baudrate: 50 bps to 921.6 Kbps (supports non-standard baudrates; see user's manual for details)

Serial Signals

RS-232: TxD, RxD, DTR, DSR, RTS, CTS, DCD, GND
RS-422: TxD+, TxD-, RxD+, RxD-, GND
RS-485-4w: TxD+, TxD-, RxD+, RxD-, GND
RS-485-2w: Data+, Data-, GND

LEDs

System: Ready x 1, SD x 1
LAN: 10M/Link x 2, 100M/Link x 2 (on connector)
Serial: TxD, RxD (2 or 4 of each)

Physical Characteristics

Housing: Aluminum (1 mm)
Weight:
 UC-7122: 190 g
 UC-7124: 200 g
Dimensions: 77 x 111 x 26 mm (3.03 x 4.37 x 1.02 in)
Mounting: DIN-Rail, wall

Environmental Limits

Operating Temperature:
 Standard models: -10 to 60°C (14 to 140°F)
 Wide temp. models: -40 to 75°C (-40 to 167°F)
Operating Humidity: 5 to 95% RH
Storage Temperature: -20 to 80°C (-4 to 176°F)

Power Requirements

Input Voltage: 12 to 48 VDC
Power Consumption:
 UC-7122: 340 mA @ 12 VDC
 UC-7124: 360 mA @ 12 VDC

Regulatory Approvals

EMC: CE (EN55022 Class A, EN61000-3-2 Class A, EN61000-3-3, EN55024), FCC (Part 15 Subpart B, CISPR 22 Class A)

Safety:

LVD: EN60950-1
 UL/cUL: UL60950-1, CSA C22.2 No. 60950-1-03

MTBF: UC-7122: 234,746 hrs.; UC-7124: 210,233 hrs.

Reliability

Alert Tools: Built-in buzzer and RTC (real-time clock)
Automatic Reboot Trigger: Built-in WDT (watchdog timer)

Warranty

Warranty Period: 5 years
Details: See www.moxa.com/warranty

Dimensions

UC-7122

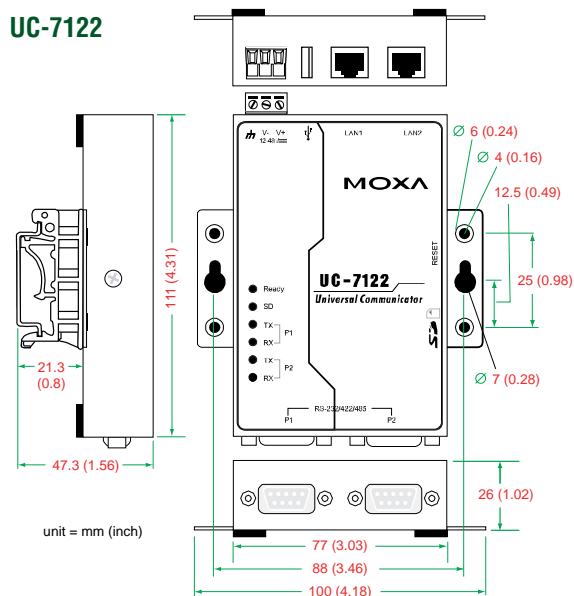

UC-7124

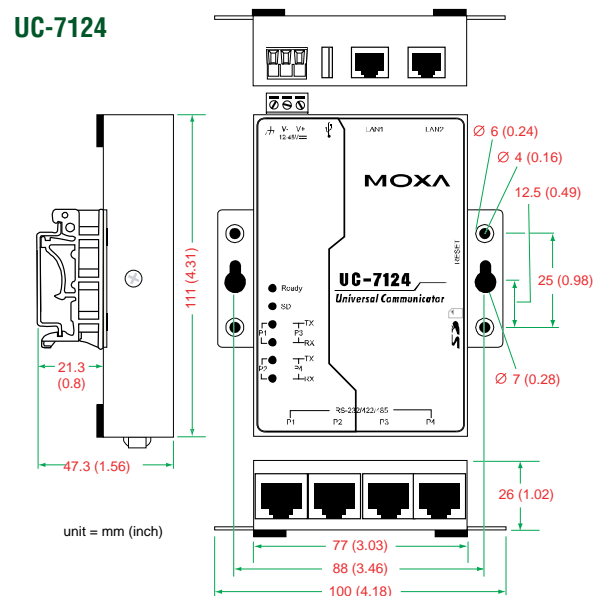

Pin Assignment

UC-7122 (DB9 male connector)

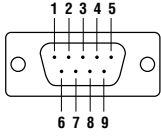

PIN	RS-232	RS-422/485-4w	RS-485-2w
1	DCD	TxD-(A)	--
2	RxD	TxD+(B)	--
3	TxD	RxD+(B)	Data+(B)
4	DTR	RxD-(A)	Data-(A)
5	GND	GND	GND
6	DSR	--	--
7	RTS	--	--
8	CTS	--	--

UC-7124 (8-pin RJ45 connector)

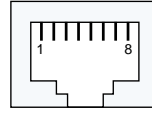

PIN	RS-232	RS-422/485-4w	RS-485
1	DSR	---	---
2	RTS	TxD+	---
3	GND	GND	GND
4	TxD	TxD-	---
5	RxD	RxD+	Data+
6	DCD	RxD-	Data-
7	CTS	---	---
8	DTR	---	---

Software Specifications

Windows Embedded CE 5.0

System Utilities: Windows command shell, telnet, ftp, web-based administration manager

File System: TFAT (on-board flash)

Protocol Stack: TCP, UDP, IPv4, SNMP, ICMP, IGMP, ARP, HTTP, CHAP, PAP, SSL, DHCP, SNTP, SMTP, Telnet, FTP, PPP

Supporting Services and Daemons:

Telnet Server: Allows remote administration through a standard telnet client.

FTP Server: Used for transferring files to and from remote computer systems over a network.

Web Server (httpd): WinCE IIS, including ASP, ISAPI Secure Socket Layer support, SSL 2, SSL 3, and Transport Layer Security (TLS/SSL 3.1) public key-based protocols, and Web Administration ISAPI Extensions.

Dial-up Networking Service: RAS client API and PPP, supporting Extensible Authentication Protocol (EAP) and RAS scripting.

Application Development Environment:

Moxa WinCE 5.0 SDK

C Libraries and Run-times

Component Services (COM and DCOM)

Microsoft Foundation Classes (MFC)

Microsoft .NET Compact Framework 2.0 SP2

Winsock 2.2

Ordering Information

Available Models

UC-7122-CE: Mini RISC-based embedded computer with 2 serial ports, dual LANs, SD, USB, WinCE 5.0 (standard operating temperature: -10 to 60°C)

UC-7124-CE: Mini RISC-based embedded computer with 4 serial ports, dual LANs, SD, USB, WinCE 5.0 (standard operating temperature: -10 to 60°C)

UC-7122-T-CE: Mini RISC-based embedded computer with 2 serial ports, dual LANs, SD, USB, WinCE 5.0 (wide operating temperature: -40 to 75°C)

UC-7124-T-CE: Mini RISC-based embedded computer with 4 serial ports, dual LANs, SD, USB, WinCE 5.0 (wide operating temperature: -40 to 75°C)

Optional Accessories (can be purchased separately)

DK-35A: Mounting Kit for 35-mm DIN-Rail

Package Checklist

- UC-7122 or UC-7124 computer
- Ethernet cable: RJ45 to RJ45 cross-over cable, 100 cm
- CBL-4PINDB9F-150: 4-pin pin header to DB9 female console port cable, 150 cm
- CBL-RJ45M9-150: 8 pin RJ45 to DB9 male serial port cable, 150 cm
- Universal power adaptor (including terminal block to power jack converter)
- Document and Software CD
- Quick Installation Guide (printed)
- Warranty Card